

General Biology Final Review

Important Concepts

dehydration reaction	tonicity	carbon fixation	allele	phenotype	viroid
hydrolysis	cofactor	coenzyme	carrier	polymer	prion
polygenic inheritance	feedback inhibition	complementary base pairing	semiconservative model	characteristics of life	reverse transcription
monomer	pleiotropy	recombinant	DNA polymerase	anticodon	retrovirus
lytic cycle	transcription	replication	linked genes	hierarchy of life	prokaryotic cell
lysogenic cycle	translation	RNA splicing	eukaryotic cell	energy flow	chemical cycle
passive transport	cytoskeleton	nucleic acids	RNA	microscopes	codon
plant organelles	covalent bond	cell junctions	protein functions	hydrogen bond	active transport
facilitated diffusion	exocytosis	endocytosis	carbohydrate	exergonic	endergonic
DNA	domains	enzyme	energy coupling	trace elements	compound
subatomic particles	atomic number	mass number	atomic mass	isotope	electron shell
hydroxyl group	carbonyl group	carboxyl group	amino group	trans fat	methyl group
laws of thermodynamics	extracellular matrix	phosphate group	saturated fatty acid	unsaturated fatty acid	natural selection
phospholipid	steroid	protein	denaturation	peptide bond	electronegativity
animal organelles	protein structures	nonpolar covalent bond	polar covalent bond	recombination frequency	endomembrane system
reactant	product	cohesion	adhesion	solute	solvent
acid	base	pH scale	buffer	carbon chains	functional group
law of independent assortment	cell cycle control system	homologous chromosome	artificial selection	oxidative phosphorylation	substrate-level phosphorylation
light reactions	Calvin cycle	diploid	binary fission	interphase	fermentation
mitosis	zygosity	redox reaction	glycolysis	haploid	meiosis
bacterial DNA transfer	chromosome alterations	probability rules	law of segregation	incomplete dominance	Hershey-Chase experiment
dihybrid cross	testcross	ionic bond	lipid	codominance	mRNA
linkage map	sex-linked genes	bacteriophage	citric acid cycle	Punnett square	tRNA
genetic variation	mutations	rRNA	spliceosome		

Questions

1. What are the seven properties of life?
2. Write down the hierarchy of life in order from the largest level to the smallest.
3. What is the difference between an ecosystem and a community?
4. What are emergent properties, and how are they important?
5. Compare and contrast prokaryotic cells and eukaryotic cells. How can the differences be used to create antibiotics?
6. Draw and describe the chemical/energy cycle for an ecosystem.
7. Why is DNA important to all organisms?
8. Compare and contrast the three domains.
9. Describe the kingdoms within the Domain Eukarya.
10. Explain what natural selection is and how it affects the changes in a species.
11. What are the two observations and inferences of natural selection?
12. What is the scientific method?
13. Complete the concept map.

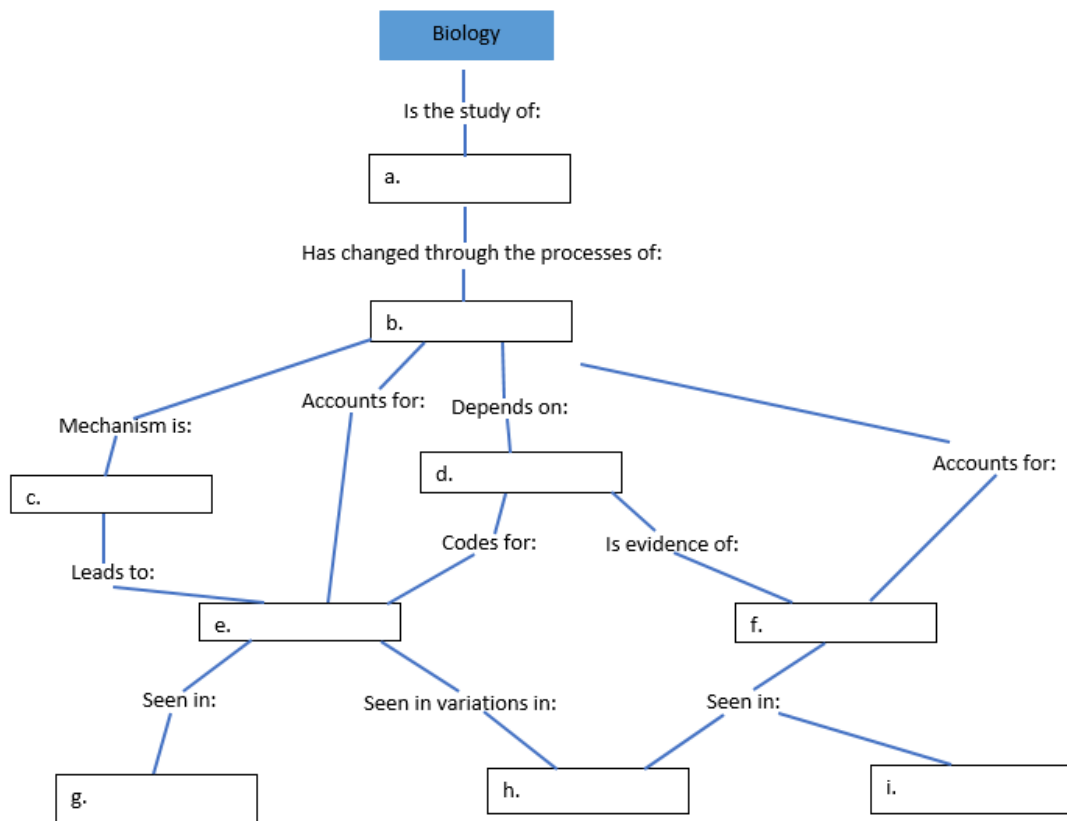

14. Which four elements make up 96% of a person's body weight?
15. Explain the difference between an element's atomic number and mass number, giving at least two examples. Use the key terms proton, neutron, and isotope.
16. How many electrons can be found in the first and second shells of an element?
17. Describe covalent, ionic, and hydrogen bonds with examples.

18. Why are hydrogen bonds and polarity important to water, and how do they give it life-supporting properties?
19. What is the major difference between adhesion and cohesion?
20. How do buffers work?
21. Which of these are ways that carbon skeletons can differ?
 - a. Branching
 - b. Double bonds
 - c. Length
 - d. All of the above
22. Name the six functional groups and their abbreviations.
23. How many biological macromolecules are there? List all of them and their monomers, if they have them.
24. What is the chemical formula of a sugar molecule with 9 carbons?
25. How do plants and animals store glucose?
26. Explain the differences between the three types of fats. How are they important in the body?
27. Which of these is NOT a possible function of proteins. List two other possible functions.
 - a. Enzymes
 - b. Storage
 - c. Denaturation
 - d. Transport
28. Using examples, draw and describe the four different structures of proteins.
29. What are the differences between DNA and RNA?
30. Compare and contrast the different microscopes. Discuss resolution, lens type, and what types/parts of cells can be visualized by each.

31. Connect each of the structures with its function.

1. nucleus	a. double chain of globular proteins that form a supportive network directly inside the plasma membrane
2. nucleolus	b. enclosed in two membranes and is used for the production of ATP
3. ribosome	c. semifluid located within a cell
4. smooth endoplasmic reticulum	d. organelle made of membranous sacs that modify, store, and ship products of the ER
5. rough endoplasmic reticulum	e. site for the synthesis of rRNA
6. Golgi apparatus	f. supercoiled fibrous proteins that reinforce cell shape and anchor some organelles
7. lysosome	g. composed of membranous compartments that converts light energy into chemical energy
8. vacuole	h. structure that works with ribosomes to make membrane and secretory protein
9. mitochondrion	i. cytoskeletal fiber that is made of globular proteins and is readily disassembled to help shape and support the cell
10. chloroplast	j. organelle made of RNA and protein that acts the site of protein synthesis
11. microtubule	k. part of the endomembrane system with metabolic functions including detoxification and calcium storage
12. microfilament	l. organelle with enzymes that transfer hydrogen atoms to oxygen, producing and then degrading hydrogen peroxide
13. peroxisome	m. large vesicles with multiple uses such as storage, digestion, and pigmentation
14. cytosol	n. sac of digestive enzymes used to break down food or damaged organelles
15. cytoplasm	o. contains the genetic instructions of a cell
16. intermediate filament	p. contents of a cell, consisting of a semifluid medium and organelles

32. Describe the general structure of cilia/flagella and how it enables them to move.

33. What are the three types of cell junctions and their functions?

34. List the four main functions of cell structures and which structures go into them. How does the shape of these molecules relate to their functions?

35. Name and describe five functions of proteins on the plasma membrane.
36. Draw both plant and animal cells in isotonic, hypertonic, and hypotonic solutions. What is the outcome of the cells in these solutions? Utilize words such as flaccid, turgid, and lyse.
37. Make a chart comparing the methods of transport across a cell membrane.
38. What is the importance of receptor-mediated endocytosis in comparison to phagocytosis?
39. Explain the first and second laws of thermodynamics with at least one example of each.
40. How does energy coupling apply to ATP? Use the words endergonic, exergonic, hydrolysis, and phosphorylation in your answer.
41. What are the steps of the catalytic cycle?
42. Write out the equations for cellular respiration and photosynthesis. How are they related?
43. Chart out all three stages of cellular respiration, listing all of the steps per stage.
44. What does it mean when glycolysis is said to have a “net yield” of 2 ATP?
45. Which of these processes does NOT occur in the mitochondria?
 - a. pyruvate oxidation
 - b. oxidative phosphorylation
 - c. citric acid cycle
 - d. glycolysis
46. If you had 7 molecules of glucose, how much ATP, NADH, and FADH₂ would be produced during each of the stages of cellular respiration? How much ATP would be produced total?
47. Which step of cellular respiration uses oxygen?
48. How much ATP is produced during fermentation?
49. Compare the two types of fermentation.
50. How do organic molecules break down to be used for cellular respiration, and how can those intermediates be used in biosynthesis?
51. What macromolecule is the best source of energy? Why?
- 52.

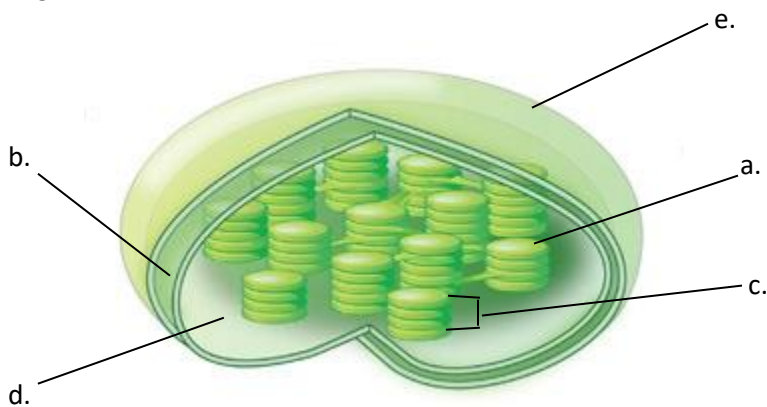

Label the diagram of a chloroplast.

53. Which of these is true for photosynthesis?
 - a. It is an endergonic process.
 - b. Oxygen is reduced during the process.
 - c. The low hydrogen ion concentration in the stroma helps power ATP synthase.
 - d. NAD⁺ is reduced to NADH during the light reactions.
54. How does wavelength relate to the amount of energy a photon has?
55. Diagram and explain the steps of the light reactions.

56. Why is the calvin cycle known as the “dark reactions?”
57. Write out the steps of the calvin cycle, including how many molecules are needed to make one G3P.
58. How many ATP are used in the calvin cycle to synthesize one glucose molecule?
59. Draw how a plant cell uses both photosynthesis and cellular respiration.
60. Why are mitochondria and chloroplasts made of folded membranes?
61. Compare and contrast the three methods of carbon fixation in plants. Why did plants adopt the other two methods?
62. What are the steps of binary fission?
63. Which organisms are benefited by binary fission?
64. Differentiate between chromatin, chromosome, and chromatid.
65. Draw a duplicated chromosome and label the chromatid, centromere, and kinetochore.
66. Diagram the steps of mitosis, including interphase.
67. How does cytokinesis differ for plant and animal cells?
68. What is the role of the cell cycle control system?
69. Where are the checkpoints in the cell cycle control system?
70. Why are the chromosomes considered to be haploid after meiosis 1?
71. Write out the steps of meiosis, including interphase.
72. After fertilization, what is the ploidy of the zygote?
73. Explain the process of crossing over.
74. List the similarities and differences between mitosis and meiosis.
75. What are the main differences between a somatic cell and a gamete?
76. Which of these are ways sexual reproduction can increase genetic variability? Circle all that apply.
 - a. independent orientation of homologs during metaphase
 - b. crossing over
 - c. chromosome duplication
 - d. different alleles on homologous chromosomes
77. How can you differentiate between nondisjunction in meiosis 1 vs meiosis 2?
78. Describe the four chromosomal alterations.
79. Why are peas good for studying heredity?
 - a. short generation times
 - b. many offspring
 - c. several observable traits
 - d. controllable breeding
 - e. all of the above
80. How did Mendel use self-fertilization and cross-fertilization to observe the passing on of traits?
81. Draw a Punnett Square of a monohybrid cross between a heterozygous inflated pea pod and a homozygous constricted pea pod.
82. What are Mendel’s four hypotheses for inheritance? What are his laws of inheritance?
83. Draw a dihybrid Punnett Square of two heterozygous individuals.
84. In Mendel’s experiments, would the generation with a 3:1 phenotypic ratio be F_1 or F_2 ?
85. What are the possible results of a testcross of a round pea seed? Draw both of them.
86. How can a testcross tell scientists what an individual’s genotypes are?

87. A plant with a genotype of $AaBBcc$ is crossed with an $aaBbCc$ plant. Using the rules of probability, what is the probability of an offspring having the genotype $AaBbCc$?
88. Complete the pedigree. Is the gene dominant or recessive?

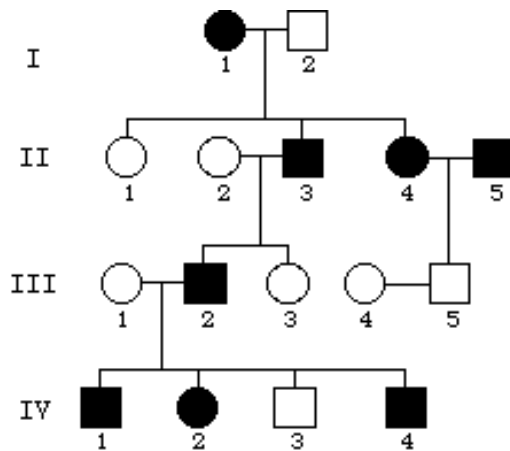

89. What are the methods of fetal genetic testing?
90. Explain the difference between incomplete dominance and codominance.
91. What is an example of incomplete dominance in humans?
92. Why are people with blood type AB called “universal recipients” and type O called “universal donors?”
93. What is the cause of recombination?
94. An experimenter did a test cross with a wild type fruit fly with two genes: body color and wing size. The wild type fly was heterozygous for both with a gray body and long wings ($Gg Ll$), and the other fly was homozygous with a black body and vestigial wings ($gg ll$). The offspring had the following phenotypes: gray long (975), black vestigial (969), gray vestigial (219), black long (185). What caused the ratio of phenotypes?
95. What is the recombination frequency of the previous question?
96. How can a researcher create a linkage map?
97. Give an example of how the environment can affect the gender of some organisms.
98. Why are males more affected by sex-linked disorders?
99. How did Hershey and Chase prove that DNA is genetic material?
100. What are the steps of replication by a bacteriophage?
101. Draw the general structure of a DNA nucleotide. Include the phosphate, base, and sugar.
102. If a chain of DNA has the following sequence, what is the matching sequence?
ATGCTACTAGATGAC
103. Differentiate between the purines and pyrimidines.
104. Write the steps of DNA replication, including the direction the daughter strand is made.
105. What is the proper order of steps from DNA to protein?
- Replication → Transcription → Translation
 - Transcription → Translation → Translocation
 - Translation → Transcription
 - Transcription → Translation
 - Translocation → Replication

106. What are the molecules of the steps in the previous question?
- DNA → RNA → polypeptide
 - DNA → DNA → polypeptide
 - RNA → DNA → polypeptide
 - RNA → RNA → polypeptide
107. How does RNA polymerase know where on the DNA to start/stop transcription?
108. How does the start/stop of translation compare to that of transcription?
109. Describe the steps of transcription.
110. What are the three RNA molecules that are important to translation, and what are their functions?
111. Which modifications happen to mRNA before it can leave the nucleus
112. Describe the steps of translation.
113. Draw out one step of polypeptide elongation, including all RNA molecules, a polypeptide chain, and the A and P sites.
114. What are the two classes of mutations, and what are individual types within those classes?
115. Why is HIV considered to be a retrovirus?
116. Explain the three ways bacteria can create recombinant chromosomes.
117. What is the importance of the F factor?

Answers

1. (pg. 2) The seven properties of life are: order, reproduction, growth and development, energy processing, regulation, response to the environment, and evolutionary adaptation. These can be further explained. Order- living cells have complex organization. Reproduction- organisms reproduce their own kind. Growth and development- Inherited information controls the pattern of growth and development. Energy processing- living organisms use chemical energy to power their activities and chemical reactions. Regulation- living organisms regulate their internal environment. Response to the environment- all organisms respond to environmental stimuli. Evolutionary adaptation- adaptations evolve over many generations as individuals with the best traits for their environment survive and reproduce.
2. (pg. 3) Biosphere, Ecosystem, Community, Population, Organism, Organ system, Organ, Tissue, Cell, Organelle, Molecule
3. (pg. 3) An ecosystem includes both the living and nonliving aspects of an environment, whereas a community involves only the living organisms.
4. (pg. 3) Emergent properties are new properties that appear when going up the levels of the hierarchy of life. They are caused by the arrangement and interactions of the pieces of the lower levels. Their importance can be written as any explanation about how the whole is more than just the sum of its parts.
5. (Found in Chapter 1 and Chapter 4. pg. 4 and pg. 55) Prokaryotic cells are simpler and smaller than eukaryotic cells. They also do not contain a membrane-enclosed nucleus. Instead it uses a nucleoid region where the chromosomes coil. While they do contain ribosomes like the eukaryotic cells, their ribosomes are smaller and slightly different. They have a cell wall to protect the cell and maintain its shape, which is different from plant cells in composition. Some prokaryotic cells also have a capsule, a sticky outer coat that helps bind the cell to other cells or surfaces. Eukaryotic cells, on the other hand, are larger and more complex with membrane-enclosed organelles, particularly the membrane-enclosed nucleus that contains the genetic material, DNA. Prokaryotic cells and eukaryotic cells have some similarities in that they both have structural components such as a plasma membrane, cytosol, chromosomes, ribosomes, and cytoplasm. (Any combination of these will work as long as prokaryotes and eukaryotes are being both compared and contrasted). These differences can be utilized for antibiotics because scientists/doctors can target structures that are present in prokaryotic cells and not in eukaryotic cells to kill them. Examples can be found on page 55.
6. (Drawing on pg. 5) There are two systems: the chemical cycling and the energy flow. The chemicals are recycled throughout the system while some energy is always lost as heat. In chemical cycling, carbon dioxide and water from the environment are converted into sugars and oxygen by producers, and sugars and oxygen are converted into carbon dioxide and water by consumers. Decomposers return chemicals back into the soil for producers to use. During energy flow, light energy is converted to chemical energy by producers, chemical energy is used by consumers, and some energy is released as heat.

7. (pg 6.) DNA is the genetic material that is passed from parents to offspring, and it codes for proteins that make up organisms and control cellular activities. Differences in species are found in how DNA is expressed differently in those organisms.
8. (pg. 7) Of the three domains, two are prokaryotic. Domains Bacteria and Archaea are prokaryotes while domain Eukarya is full of diverse eukaryotes. Bacteria are the most widespread and diverse, but archaea are known for being able to withstand extreme environments.
9. (pg. 7) Eukarya has many kingdoms including protists, Fungi, Plantae, and Animalia. Protists are largely diverse, single-celled organisms. Plantae consists of all plants, which produce energy via photosynthesis. Fungi contains decomposers, and Animalia has animals that act as consumers.
10. (pg.8-9) Natural selection is the process that allows organisms that are best suited to their environments to survive and reproduce over other organisms. Individuals in a population have variation in their traits, and those with the traits that allow them to survive in the environment can pass the traits onto their offspring. Accumulation of the favorable traits leads to different species and even completely different organisms through evolution over a long period of time.
11. (pg. 8) Observation 1: individual variation. Observation 2: overproduction of offspring. Inference 1: unequal reproductive success. Inference 2: accumulation of favorable traits over time.
12. (pg. 10; possibly in lab notebook as well) The steps of the scientific method include: Observation, Question, Hypothesis, Prediction, Test, Results/Conclusion. If a hypothesis is found to be rejected, another hypothesis can be made and tested.
13. (pg. 13 or pg. A-4) a. life; b. evolution; c. natural selection; d. DNA; e. diversity of life; f. unity of life; g. three domains; h. cells as basic units of life; i. common properties of living organisms
14. (pg 18.) Oxygen, carbon, hydrogen, and nitrogen account for the majority of body weight.
15. (pg. 20) The atomic number of an element is the number of protons in that element. The mass number is the number of protons added to the number of neutrons. This number can be different depending on what type of isotope of that element is present. An isotope is an element with a different number of neutrons. An example of this is carbon, which has three isotopes: Carbon-12, Carbon-13, and Carbon-14. Carbon has 6 protons, but its isotopes have 6, 7, and 8 neutrons, respectively. Nitrogen also has isotopes: Nitrogen-14 and Nitrogen-16.
16. (pg. 22) There are two electrons in the first shell, and the second shell can hold up to eight electrons.

17. (pg. 23-25) Covalent bonds are bonds that are made when atoms that have unpaired electrons share those electrons. These bonds can be nonpolar - where the bonds are shared equally between the atoms - like methane. They can also be polar - where the bonds are shared unequally because one or more of the atoms is more electronegative than the other(s) - like water. Ionic bonds are bonds that are made when a highly electronegative atom takes one or more electrons from a less electronegative atom, and the attraction between the charged atoms keeps them together. A good example of this is NaCl because the chlorine takes an electron from the sodium to make a positive sodium ion and a negative chloride ion. The positive and negative charges attract each other and maintain the bond. Hydrogen bonds are weak bonds that form when polar compounds are near polar compounds with hydrogen. The partially positive charge in the hydrogen is attracted to the partially negative charge in the polar compound, and that forms the weak bond. The best example of hydrogen bonding is the hydrogen bonds in water between the hydrogens of one water molecule and the oxygens of other water molecules.
18. (pg. 26-27) Because there are so many hydrogen bonds in water, they give it life-supporting properties such as adhesion, cohesion, and temperature regulation. Adhesion is when one substance clings to another, such as water adhering to cell walls in plants to avoid the pull of gravity. Cohesion is when one substance clings to itself. This can be seen when water striders stand on top of water, and their bodies are held up solely by the cohesive forces that cause surface tension. These two properties are caused by the sheer number of hydrogen bonds within bodies of water. Water temperature can also be moderated by the large number of hydrogen bonds because energy must be absorbed to break those bonds. This means that it takes a longer amount of time to heat and cool large bodies of water. The water temperature can also be regulated in polar regions by the density of water as opposed to ice. Because ice holds the hydrogen bonds in place, it allows for more space between the water molecules. This leads to the ice floating while the water below can stay below freezing temperatures and hold living organisms. The polarity of water allows it to be one of the main dissolving agents, solvents, in a solution. The partial positive charges of the hydrogens and the partial negative charges of the oxygens help attract the negative and positive portions of the solutes, respectively.
19. (pg. 26) Cohesion is when molecules of the same kind stick together, and adhesion is when two different molecules stick together.
20. (pg. 28) Buffers minimize changes in pH by accepting or donating H^+ , depending on which is needed.
21. (pg. 34) D
22. (pg. 35) hydroxyl: OH; carbonyl: C=O; carboxyl: COOH; amino: NH_2 ; phosphate: OPO_3^{2-} ; methyl: CH_3
23. (pg. 37, 40, 43, and 46) There are four biological macromolecules: carbohydrates, lipids, nucleic acids, and proteins. Their monomers are monosaccharides, nucleotides, and amino acids, with the exclusion of lipids. Lipids are different from the other three macromolecules in that they are not built from similar monomers. Instead, there are three main types of lipids: fats, phospholipids, and steroids. Fats are made of three fatty acids and glycerol; phospholipids are made of two fatty acids, glycerol, and a phosphate group; and steroids are made of four carbon rings and different chemical groups.

24. (pg. 37) The standard formula for a sugar molecule is CH_2O , so this would be $\text{C}_9\text{H}_{18}\text{O}_9$.
25. (pg. 39) Plants use the polysaccharide starch, and animals use glycogen. Both of these polysaccharides can be broken down into glucose for energy.
26. (pg. 40-41) The three types of fats differ structurally, which allows them to function differently. They include unsaturated fats, saturated fats, and trans fats. Unsaturated fats contain fatty acids with double bonded carbons somewhere along them, which causes a bend in the carbon chain. These fats are typically liquids at room temperature and are referred to as oils. Saturated fats have fatty acids where all of the carbons are fully saturated, meaning there are no double bonds present. This causes the hydrocarbon chains to be straight, which allows them to be solid at room temperature. Trans fats are unsaturated fats that have been converted to saturated fats by adding hydrogen to the fatty acid chains. Fats in general are used for long-term energy storage. However, large consumption of saturated fats has been linked to heart disease, with consumption of trans fats being even worse.
27. (pg. 43) C; contractile proteins, receptor proteins, and structural proteins
28. (pg. 45) Drawings can vary, but a basic outline can be found on page 45. The four structures of proteins are primary, secondary, tertiary, and quaternary. The primary structure is the general arrangement of amino acids. The secondary structure is the coiling/folding of the amino acid chains into either alpha helices or beta pleated sheets. These are held together typically by hydrogen bonds. The tertiary structure is the 3D structure of a protein. This is maintained by hydrogen bonds, ionic bonds, disulfide bridges, and other interactions between R groups. There can be multiple secondary structures within one tertiary structure. Quaternary structure is when a protein is made of more than one polypeptide chain, where all the chains are called subunits of the whole protein. Interactions similar to those in tertiary structures maintain the quaternary structures.
29. (pg.46-47 and pg. 184-185) DNA is made of a double stranded helix, uses thymine, and has the main sugar deoxyribose. RNA is a single strand, uses uracil, and has the main sugar ribose.
30. (pg. 52-53) The light microscope is the oldest functioning microscope, and it uses light to pass through a specimen and glass lenses. It typically has a resolution between $0.2\ \mu\text{m}$ and $0.1\ \text{mm}$. Overall, it can be used to look at general cell structure, some structures within the cell, and living specimens. There are two electron microscopes, both of which focus a beam of electrons through or onto a specimen. Electron microscopes use electromagnets as their lenses, and they have a higher resolution of $2\ \text{nm}$. Of these two, the scanning electron microscope is used to study the surface of cells, while the transmission electron microscope is used to study internal cell structure. An SEM sends electrons to the surface of a specimen that is usually coated with a film of gold, and the electron beam excites electrons on the surface of the gold. These excited electrons are then detected by the microscope and translated onto a screen. A TEM sends electrons through a section of the specimen, which is stained with heavy metals that attach to the cellular structures. The electrons are scattered at dense regions, and the microscope creates an image of those transmissions.

31.

1.	o.
2.	e.
3.	j.
4.	k.
5.	h.
6.	d.
7.	n.
8.	m.
9.	b.
10.	g.
11.	i.
12.	a.
13.	l.
14.	c.
15.	p.
16.	f.

32. (pg. 66-67) Cilia and flagella have the same general structure that is known as the 9 to 2 pattern, meaning that nine doublets of microtubules surround a pair of central microtubules. Y shaped motor proteins called dyneins are between the doublets, and they move in a walking pattern along the microtubules. The movement is coordinated to allow movement only on one side of the cilia/flagella. Based on the coordination, cilia and flagella move differently: cilia work together like the oars of a ship, and flagella whip around in an undulating pattern.
33. (pg. 68) The three cell junctions are the tight junction, anchoring junction, and gap junction. The tight junction is a mesh of proteins that prevents fluid leakage across cells. Anchoring junctions are intermediate filaments that hold adjacent cells together. Gap junctions are pores that allow small molecules to flow between cells, which in turn provides a means of communication between cells.

34. (pg. 69) The four main functions are genetic control; manufacturing, distribution, and breakdown of materials; energy processing; and structural support, movement, and communication between cells. Table 4.22 lists which structures go into these groups. There is a basic general structure within each of the groups. Genetic control is led by organelles with the ability to read and replicate nucleic acids. Organelles that work with manufacturing and breakdown of materials are made of interconnected membranous sacs. Energy processing organelles have a large surface area and metabolically active membranes. Structural support organelles are made of various protein fibers. These similar structures allow all organelles in the four groups to function both individually and as integrated systems.
35. (pg. 74) Answers may vary. Enzymes act as catalysts to speed up a reaction. Attachment proteins connect the extracellular matrix to the cytoskeleton and provide support as a means of communication between the two. Receptor proteins receive signaling molecules, and they relay the message those molecules communicate by activating molecules inside the cell. Channel proteins allow small ions and polar molecules in and out of the cell. Active transport proteins allow specific molecules into and out of the cell by expending energy. Junction proteins attach adjacent cells. Glycoproteins act as cellular tags and allow the cell to be recognized by other cells.
36. (pg. 77) Drawings on Figure 5.5. In a hypotonic solution, animal cells will swell as water follows the higher concentration of solute, and they will lyse, or burst. Plant cells function normally in a hypotonic solution, so the cells will be turgid. Animal cells function normally in an isotonic solution, but plant cells will lose water and become flaccid as water follows the higher concentration of solute. Both animal and plant cells will shrivel in a hypertonic solution, and if the solution is extremely concentrated, plant cells may even plasmolyze, where the plasma membrane separates from the cell wall.
37. Charts may vary.

Diffusion	Facilitated Diffusion	Active transport	Exocytosis	Phagocytosis	Receptor-Mediated Endocytosis
small, nonpolar molecules; passive transport; follows the concentration gradient	small, polar molecules and ions; passive transport through a channel; follows the concentration gradient	requires energy to move solutes; goes against the concentration gradient	large molecules; full transport vesicles fuse with the plasma membrane and release contents into the extracellular matrix	large molecules; endocytosis; a cell engulfs a particle and forms a vacuole that fuses with a lysosome for digestion	large molecules; a molecule binds to a receptor, which causes the plasma membrane to form a coated pit that engulfs the molecules of interest and forms a vesicle that releases its contents into the cytoplasm

38. (pg. 79) Receptor mediated endocytosis gives the cell a means of selectively bringing in certain molecules because they have to first bind to receptors for just those molecules.

39. (pg.80) The first law of thermodynamics states that energy cannot be created or destroyed. A good example of this would be during cellular respiration where glucose and oxygen are converted into carbon dioxide, water, chemical energy, and heat energy. None of the energy has been created or destroyed. The potential energy in the reactants was converted into different forms of energy in the products. The second law of thermodynamics states that energy conversions increase the entropy of the universe. This can also be seen in cellular respiration because some of the potential energy that was used in the reaction is lost as heat energy, which increases entropy because this heat energy is not being used by the cell.
40. (pg. 81-82) Energy coupling is when the energy produced by exergonic reactions is used to power endergonic reactions. A very good example of this is the synthesis and hydrolysis of ATP. ATP synthesis is endergonic because the product, ATP has a high potential energy. The exergonic process that is coupled with this synthesis is cellular respiration, which uses energy to break down glucose. This coupling is only one step of the ATP cycle, however. The exergonic process used to break apart ATP, hydrolysis, is also coupled with the phosphorylation of another molecule. Phosphorylation is the transfer of one of the high energy phosphate groups from ATP to another molecule. The potential energy from ATP is transferred to molecules such as chemical reactants, transport proteins, and motor proteins in the form of the phosphate group. This yields ADP and phosphate after the process is over, which can then be cycled through to cellular respiration again.
41. (pg. 84) At the beginning of the catalytic cycle, a specific substrate finds an enzyme with an empty active site and enters it. The enzyme then folds over the substrate to form an induced fit. The substrate will be converted to products and be released from the enzyme, which is ready to begin the cycle again after the active site is emptied.
42. (pg. 91 and 110) Cellular respiration: $C_6H_{12}O_6 + 6O_2 \rightarrow 6CO_2 + 6H_2O + ATP + \text{heat}$
Photosynthesis: $\text{light energy} + 6CO_2 + 6H_2O \rightarrow C_6H_{12}O_6$ Cellular respiration and photosynthesis are complementary processes. The products of one can be used as the reactants of the other.

43. (pg. 95-98) The three stages of cellular respiration are glycolysis, the citric acid cycle, and oxidative phosphorylation. Drawings may vary. A basic example of what is recommended is provided.

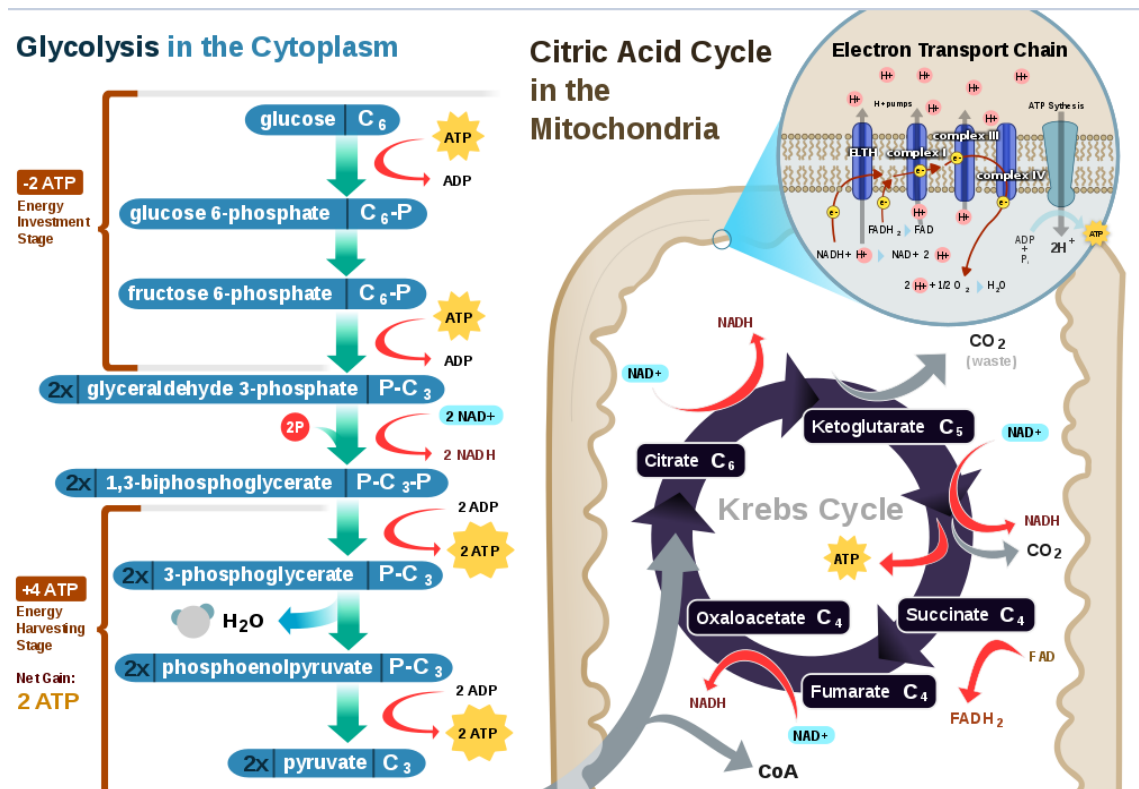

44. (pg. 94-95) Glycolysis has two phases: an energy investment phase, and an energy payoff phase. During the energy investment phase, 2 ATP are used to make reactive intermediates from the original glucose. During the energy payoff phase, other intermediates in the reaction provide the phosphates needed for substrate-level phosphorylation of 4 ADP molecules to ATP. Because 2 ATP were originally used to move the reaction along, net yield of ATP is only 2.
45. (pg. 93) D
46. (pg. 100) If there were 7 molecules of glucose, the yield per stage would be multiplied by seven. Glycolysis would produce 14 ATP and 14 NADH. Pyruvate oxidation would produce 14 NADH, and the citric acid cycle would make 42 NADH, 14 $FADH_2$, and 14 ATP. Oxidative phosphorylation then yields 196 ATP through the use of NADH and $FADH_2$ molecules. The total ATP produced for cellular respiration would be 224 ATP.
47. (pg. 98) During oxidative phosphorylation, oxygen is the final electron acceptor of the electron transport chain. It is converted into water when two hydrogens are added to it.
48. (pg. 100) Fermentation has a net yield of 2 ATP because it uses glycolysis and an NADH recycling path.

49. (pg. 101) When oxygen isn't present, organisms can use either lactic acid fermentation or alcohol fermentation. Lactic acid fermentation regenerates NAD^+ by oxidizing NADH and reducing pyruvate to lactate. The lactate is then carried away via the blood to the liver to be converted to pyruvate and used in the mitochondria. Alcohol fermentation is more common in yeasts. NADH is oxidized while pyruvate is converted to CO_2 and ethanol. Both of these products are then released into their surroundings. If ethanol is not released, it becomes toxic to the yeast.
50. (pg 102-103) A chart is recommended. Carbohydrates are broken down into sugars and eventually glucose, which can go through cellular respiration. Fats can be broken down into glycerol and fatty acids. The glycerol can easily be converted into G3P, an intermediate of glycolysis. Fatty acids can be broken down into acetyl CoA to go through the citric acid cycle. Proteins are very pliable and can be broken down into intermediates of glycolysis or the citric acid cycle. They can even be converted into acetyl CoA. For the biosynthesis of these molecules, you take the corresponding intermediates and convert them into carbohydrates, fats, and proteins, respectively. These macromolecules can then be used throughout the body.
51. (pg. 102) Fats are the best macromolecules for energy because they have many hydrogen atoms and can be broken down and cycled through to make acetyl CoA from fatty acids and G3P from glycerol.
52. (pg. 109)
- thylakoid
 - inner membrane
 - granum
 - stroma
 - outer membrane
53. (pg. 111) A: photosynthesis is endergonic
54. (pg. 112) High energy photons result from short wavelengths, and low energy photons result from long wavelengths.

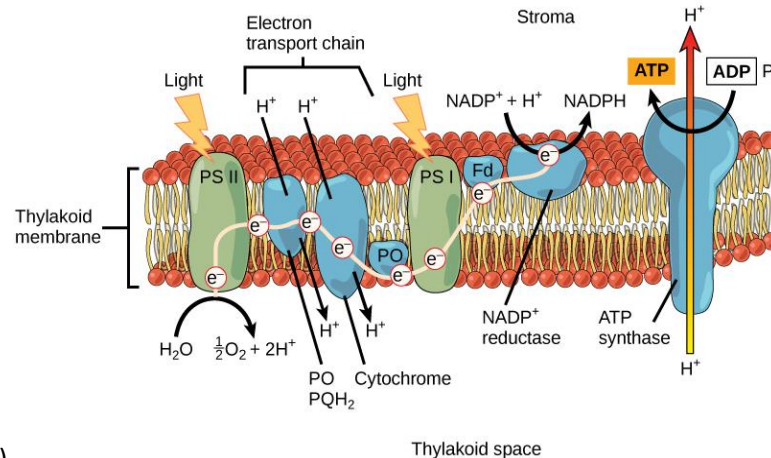

55. (pg. 114-115) Diagrams may vary, but an example is given.
- In the light reactions, the light energy that is absorbed by chlorophyll a pigments in the reaction center of photosystem 2 is used to energize electrons that are donated by water. Water is broken down into its oxygen and hydrogen components, and the energized electrons are captured by the primary electron acceptor in photosystem 2. These energized electrons are then passed through an electron transport chain that pump hydrogen ions into the thylakoid space, increasing the hydrogen concentration. Photosystem 1 then absorbs more light energy to energize the electrons once more, where they go to the primary electron acceptor, are passed through a small electron transport chain, and are delivered to NADP^+ to reduce it into NADPH. The high hydrogen concentration in the thylakoid space is then used to power ATP synthase to produce ATP. NADPH and ATP are then sent to the Calvin cycle.
56. (pg. 111) None of the steps of the calvin cycle require light energy directly.
57. (pg. 116) There are four steps of the Calvin cycle. Step 1 involves carbon fixation where rubisco combines CO_2 with three molecules of RuBP. This splits into six molecules of 3-PGA. At step 2, 3-PGA is reduced into G3P by oxidizing six NADPH and using six ATP for energy. Step 3 is the release of G3P, but only one G3P is released, while the other five molecules of G3P remain in the cycle. Using the power of three ATP, step 4 is the regeneration of three RuBP molecules from the five G3P molecules that were not released. RuBP is then reused in the cycle.
58. (pg. 116) Glucose is produced from two G3P, so the amount of ATP needed in the calvin cycle would be 18, giving 9 ATP per G3P molecule.

59. (pg. 93, 95-98, 100, 111, 115-116)

PHOTOSYNTHESIS RESPIRATION

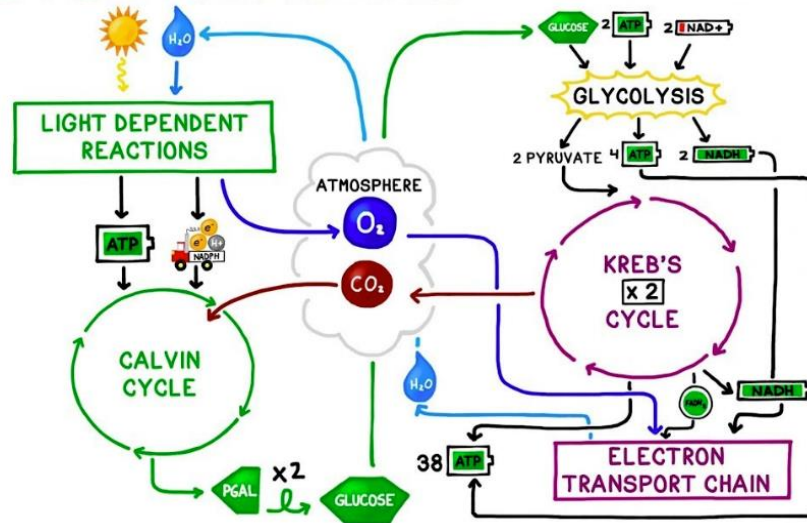

Diagrams may vary, but a simplified example is shown. Students are recommended to emphasize that photosynthesis occurs in the chloroplasts while cellular respiration occurs in the mitochondria of the same cell.

60. (pg. 63) Folding the membranes increases the surface area, which allows both the mitochondria and chloroplasts to make vast quantities of their respective products.
61. (pg. 117) The most common method of carbon fixation is used in C_3 plants, which is when the enzyme rubisco adds CO_2 to RuBP. They are known as C_3 plants because the product of the fixation is the three carbon 3-PGA. The other two methods of carbon fixation are adaptations to hot, dry environments. If a C_3 plant were to try to survive in a hot environment, it would close its stomata to prevent water loss, which prevents CO_2 from entering the cell and O_2 from leaving. The two methods adapted to these environments are C_4 and CAM plants. C_4 plants fix CO_2 into a four-carbon compound in a mesophyll cell. When the weather is hot and dry, the stomata close, and the four-carbon compound can be shuttled to bundle-sheath cells to be converted into CO_2 and used in the calvin cycle. CAM plants only require one cell. It also converts CO_2 into a four-carbon compound, but it only opens its stomata at night. This allows the carbon dioxide to enter the cell and be stored throughout the night, and when the sun rises and the stomata close, the four-carbon compound can be converted into CO_2 and used in the calvin cycle.
62. (pg. 127) The prokaryotic chromosome duplicates. The cell elongates, and the copies move to opposite ends while the chromosome continues duplicating. The plasma membrane grows inward, and more cell wall is made.
63. (pg. 127) Prokaryotes reproduce via binary fission, which includes bacteria and archaea.
64. (pg. 128) A chromatin is a diffuse mass of DNA and proteins. Chromosomes are the result of chromatin fibers coiling before cell division. These chromosomes are made of two sister chromatids, which are the two halves of the chromosome. Chromatid are two copies of the original chromosome that occur after duplication.

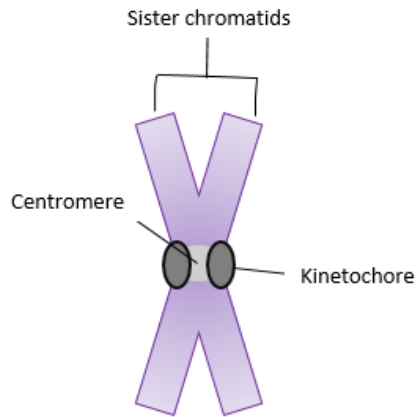

65. Drawings may vary. The centromere is the region that includes both kinetochores.
66. (pg. 130-131) Diagrams can be found in the book. Interphase is the growth phase with G_1 , S, and G_2 . During the S phase of interphase, the chromatin fibers duplicate. Mitosis includes: PMAT. Prophase is the condensing of the chromatin into chromosomes, and mitotic spindles forming. Prometaphase includes the breaking of the nuclear envelope, the attachment of spindles to the kinetochores of chromosomes, and the movement of those chromosomes towards the center. Metaphase is when the chromosomes align at the metaphase plate with each sister chromatid facing opposite poles. Anaphase is the step that separates the sister chromatids by shortening the mitotic spindles attached to the now-chromosomes and lengthening the spindles that are not. This also results in the cell lengthening. Telophase and cytokinesis often happen simultaneously, where the cell is pinched off in the middle, the nuclear envelope reforms, the chromosomes uncoil, and the spindles disappear.
67. (pg. 132) Because of the presence of the cell wall in plants, it must divide differently. Animal cells use microfilaments at the center of the cell, which, when the actin and myosin filaments interact, will contract and pinch the cell apart into two. Plant cells use vesicles that move to the center of the cell and fuse to form the cell plate. The cell plate grows outward by adding more vesicles until it fuses with the plasma membrane and forms two cells.
68. (pg. 134) The cell cycle control system coordinates certain events in the cell cycle. It has three checkpoints where the default is to stop at each unless given go signals.
69. (pg. 134) The three checkpoints are found at G_1 , G_2 , and between metaphase and anaphase (M).
70. (pg. 137-139) After duplicating, the homologous chromosomes form a tetrad. When homologs are separated at the end of meiosis 1, each cell has a single chromosome set, meaning that the chromosomes are made of two sister chromatids, but they no longer form the paired set of homologous chromosomes to make them diploid.

71. (pg. 138-139) A diagram is recommended. Interphase- cell growth and chromosomes duplicate. Prophase 1- chromosomes coil; nuclear envelope breaks; spindle forms; homologous chromosomes come together (synapsis) to form a tetrad; crossing over. Metaphase 1- tetrads align at the metaphase plate; homologous chromosomes are held together at crossing over points still. Anaphase 1- homologous chromosomes move to opposite poles of the cell; spindles attached to chromosomes shorten; spindles not attached lengthen. Telophase 1/Cytokinesis- cell pinches into two. Prophase 2- spindles form; chromosomes begin moving to the center. Metaphase 2- chromosomes align at the metaphase plate. Anaphase 2- chromosomes are pulled apart; sister chromatids are not labeled as chromosomes. Telophase 2/Cytokinesis; cell pinches off into two; nuclear envelope forms; spindle disappears; chromosomes condense. 4 haploid daughter cells are made.
72. Ploidy is if something is haploid, diploid, or other. When an egg is fertilized, the haploid egg combines with a haploid sperm to create a diploid zygote.
73. (pg. 138; 142-143) Within homologous chromosomes, non-sister chromatids - chromatids not from the same pair - are exchanged. The steps of this are: breaking, joining, separation of homologs, separation of chromatids. The non-sister chromatids break at the same locations and then immediately join. This area where they meet is known as the chiasma. The chromatids remain attached until anaphase 1, where homologous chromosomes separate. All chromatids separate at anaphase 2, leaving two recombinant chromosomes and two parent chromosomes.
74. (pg. 140) Mitosis- duplicated chromosomes are present at prophase; sister chromatids separate during anaphase; two genetically identical diploid daughter cells; used for growth, tissue repair, and asexual reproduction. Meiosis- homologous chromosome pairs are present at prophase 1 (tetrads); homologous chromosomes separate during anaphase 1, but sister chromatids separate during anaphase 2; two divisions; four genetically unique haploid daughter cells; used for sexual reproduction. Both- duplicated chromosomes during interphase; chromosomes line up at the metaphase plate.
75. A somatic cell is a body cell, and it is typically diploid. Gametes are sex cells, and they are haploid.
76. (pg. 141-142) a, b, d
77. (pg. 144) If you look at the four resulting gametes, the number of chromosomes in each shows where nondisjunction occurred. If nondisjunction occurred in meiosis 1, there will be two abnormal gametes with three of the same chromosome. If it occurred in meiosis 2, there will be one abnormal gamete with three of the same chromosome.
78. (pg. 148) Deletion- a segment of a chromosome is removed. Inversion- a segment of a chromosome is removed and reinserted opposite to its original position. Duplication- a segment of a chromosome is copied and inserted into the homolog. Reciprocal translocation- segments of two nonhomologous chromosomes swap locations with each other.
79. (pg. 154-155) e

80. (pg. 155) The fertilization technique Mendel used required he cover the plants with a bag for self-fertilization. For cross-fertilization, he would cut off the stamens and dust the carpels with the desired pollen. This technique allowed him to selectively pollinate peas for desired traits. The P generation, or the parent generation, would be the originally self-fertilized plants that only produced one trait. He then made hybrids by crossing two different parents, such as purple flowered plants with white flowered plants, to make the F₁ generation. From that generation, he would self-fertilize those again and observe their offspring, the F₂ generation. The results of the cross-fertilization would be seen in the physical traits of the F₂ generation especially.

81.

	I	i
i	Ii	ii
i	Ii	ii

82. (pg. 156, pg. 158) 1. There are alleles, which are alternative forms of genes. 2. An organism inherits two alleles, one from each parent. Aa is heterozygous; AA and aa are homozygous. 3. Dominant alleles determine the phenotype in heterozygotes. 4/1. The law of segregation- Allele pairs segregate/separate during meiosis. 2. Law of independent assortment- the inheritance of one gene doesn't affect the inheritance of others.

83. (pg. 158)

	RY	rY	Ry	ry
RY	RRYY	RrYY	RRYy	RrYy
rY	RrYY	rrYY	RrYy	rrYy
Ry	RRYy	RrYy	RRyy	Rryy
ry	RrYy	rrYy	Rryy	rryy

84. (pg. 158) These would be F₂ because they are the cross of two heterozygous parents.

85.

	R	R
r	Rr	Rr
r	Rr	Rr

	R	r
r	Rr	rr
r	Rr	rr

86. By the definition of a testcross, we know that one of the parents will be homozygous recessive. If a monohybrid cross is done with a parent that shows the dominant phenotype, there are only two possibilities for the genotype. After the cross, the ratio of the offspring will show which genotype the unknown parent has. If the ratio of the offspring matches the predicted ratio of a particular genotype, the parent can be said to have that genotype.

87.

	A	a
a	Aa	aa
a	Aa	aa

	B	B
B	BB	BB
b	Bb	Bb

	C	c
c	Cc	cc
c	Cc	cc

$\frac{1}{2} * \frac{1}{2} * \frac{1}{2} = \frac{1}{8}$ The probability of getting each of those phenotypes individually is $\frac{1}{2}$. The probability of getting Aa AND Bb AND Cc would be found multiplying all three individual probabilities.

88.

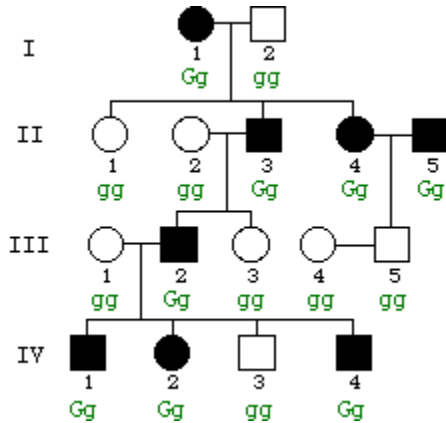

Dominant. This can be seen as dominant because II : 4 and 5 produce two offspring without the trait, showing that it cannot be recessive. If two recessive parents passed it on, the offspring would have the same genotypes as the parents.

89. (pg. 164-165) They are amniocentesis and chorionic villus sampling. Amniocentesis is when a needle is used to extract amniotic fluid. CVS is when a tube extracts a sample of the chorionic villus tissue from the placenta through vagina.
90. (pg. 166-167) Incomplete dominance is seen when the dominant allele doesn't completely mask the recessive allele. A good example of this is pink flowers coming from white and red flowers. Codominance is seen in genes that have multiple dominant alleles, and those alleles, if present together, can be expressed at the same time. An example in humans is blood type, where both the A carbohydrate and B carbohydrate are dominant alleles.
91. (pg. 166) Hypercholesterolemia: heterozygotes have blood cholesterol that is twice as high as normal, and homozygous recessive individuals have about five times as much cholesterol in the blood as normal.

92. (pg. 167) AB individuals have both the A carbohydrate and the B carbohydrate on their red blood cells, so they will not reject blood that has the carbohydrates on it. Typically, blood cells reject something they don't have, so if it has both, it won't react. O individuals are universal donors because they have neither carbohydrate, meaning that whoever receives the blood will not react negatively to "foreign" substances.
93. (pg. 172-173) Crossing over is the cause of recombinant alleles.
94. (pg. 173) The recombination of linked genes during crossing over created this ratio.
95. (pg. 173) $404 \text{ recombinants} / 2,348 \text{ total offspring} = 0.172 = 17.2\%$
96. (pg. 174) When observing linked genes, how far apart two genes are can be seen in their recombination frequency. The farther apart two genes are, the higher chance they have of crossing over, so the higher their recombination frequency. A researcher can use this concept to compare multiple genes by seeing the recombination frequencies between all of the genes they are observing. If they were observing genes A, B, and C, they would find the frequencies between A-C, A-B, and B-C. The larger frequencies correspond to distances farther away, and the smaller frequencies correspond to closer ones. This allows the researcher to place those genes along the chromosome, thus creating a linkage map.
97. (pg. 175) For some reptiles, the temperature of the eggs' incubation determines the gender. For example, with green sea turtles, cooler temperatures lead to females, and warmer temperatures lead to males.
98. (pg. 177) When a sex-linked disorder is recessive, an individual must be homozygous for that gene. This would mean that females need two copies of the recessive gene, one from the mother and one from the father, to inherit the trait. Males, on the other hand, only require one because they have one X chromosome that they receive from the mother. If a female is a carrier for the trait, she is more likely to pass that trait off to her sons.
99. (pg. 182-183) They had two batches of radioactively labeled phages: one with radioactively labeled protein (How did Hershey and Chase prove that DNA is genetic material?)
100. (pg. 183 and 200) There are two forms of replication in viruses: the lytic cycle and the lysogenic cycle. After a phage injects its DNA into the cell, the DNA becomes circular and can enter either cycle. In the lytic cycle, the host chromosome is used to make new phage DNA and proteins, and those pieces assemble into new phages. The new phages then burst from the host, lysing the cell and allowing the phages to infect new hosts. In the lysogenic cycle, the phage DNA is inserted into the host chromosome, where it is now known as a prophage. The host cell then replicates its DNA with the new DNA like normal, creating many daughter cells with the viral DNA within them. No phage proteins are made, but the DNA is spread to many bacteria without lysing the cell. With environmental stress, lysogenic cells can excise the phage DNA and switch to the lytic cycle.

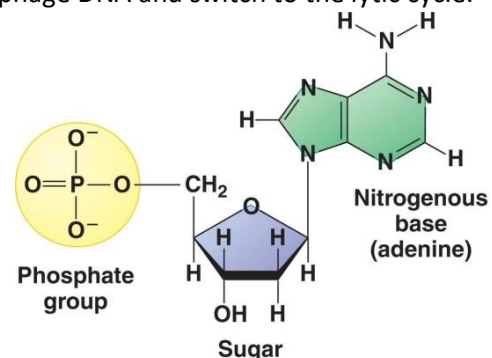

101. (pg. 185) Drawings may vary depending on the base.

102. TACGATGATCTACTG

103. (PG. 185) Thymine, Uracil, and Cytosine are pyrimidines, which are single-ring structures. Adenine and Guanine are purines, which are double-ring structures. Remember: pyramids are sharp and CUT.

104. (pg. 188-189) At the origin of replication, the DNA is unzipped and untwists. Two different DNA polymerases attach to the two strands, and it begins attaching free-floating DNA nucleotides to the daughter strand, adding to the 3' end. Because one of the strands is facing the opposite direction, it must be pieced together in Okazaki fragments, so the polymerase can add to the 3' end. The other strand grows continuously in a 5' - 3' direction. DNA ligase then links the nucleotides together, which allows a complete, identical daughter strand to be made.

105. (pg. 191) d

106. (pg. 191) a

107. (pg. 193) On DNA, there is a promoter region and a terminator region. The promoter region is the site where the RNA polymerase binds and starts transcription. The terminator region signals the end of a gene, and the RNA polymerase can detach.

108. (pg. 192,196-197) The initiator tRNA binds to the start codon, AUG, to start translation. At one of the stop codons (UAA, UAG, or UGA), the newly formed peptide is released.

109. (pg. 193) There are three steps: initiation, elongation, and termination. During initiation, RNA polymerase attaches to the promoter segment of DNA and starts RNA synthesis. RNA polymerase acts much like DNA polymerase in that it adds nucleotides onto the sequence from within the intracellular environment. Elongation is the continuation of RNA synthesis, and the RNA molecule grows away from the DNA template, allowing the DNA to come back together. Termination occurs when RNA polymerase reaches the terminator DNA and detaches from both the RNA and the DNA.

110. (pg. 194-196) The three RNA molecules are: mRNA, tRNA, and rRNA. mRNA is the main RNA that holds the template that was transcribed from DNA. It carries the code for the proteins. tRNA is the RNA that binds to mRNA at the codons and carries the amino acids. It has two ends: an end with the anticodon and an end with the corresponding amino acid. rRNA makes up the ribosomes. Ribosomes are made of a large subunit and a small subunit, both of which are made of rRNA. When a ribosome is together, it holds together the mRNA and the tRNA and forms peptide bonds between the amino acids.

111. (pg. 194) RNA splicing and the addition of the 5' cap and 3' tail. The splicing removes the introns and splices together the exons. The cap and tail prevent degradation of the mRNA.

112. (pg. 196-197) Like transcription, there are three main steps: initiation, elongation, and termination. Initiation begins when an mRNA molecule binds to the small ribosomal subunit, and the initiator tRNA binds to the start codon of the mRNA sequence. The large ribosomal subunit binds to the small one with the initiator tRNA at the P site of the ribosome. Elongation involves new tRNA coming into the A site of the ribosome, and recognizing the corresponding codon. The amino acid on the tRNA then binds to the peptide chain, and the ribosome catalyzes peptide bond formation. The old tRNA then leaves the P site, and the tRNA with the peptide bond is translocated from the A site to the P site. (an APE is APT: A site → P site → Exit; Anticodon → Peptide bond → Translocation) Elongation occurs until the mRNA reaches the stop codon. Then, the polypeptide is released and the ribosome and RNA pieces separate.

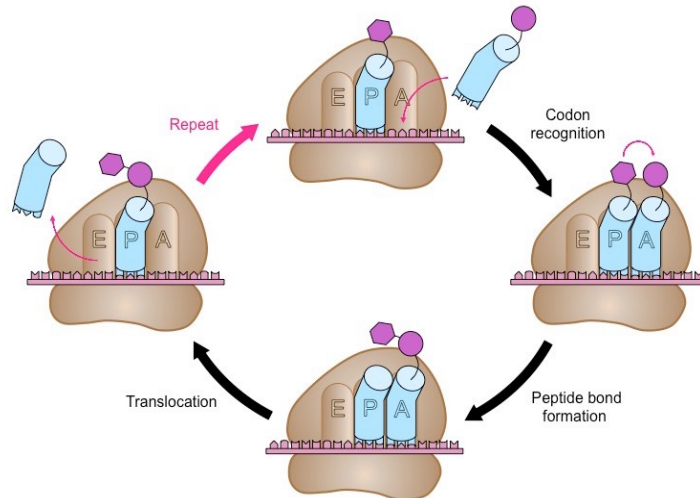

113. (pg. 197) [The image in this answer includes a hyperlink to a video of translation in motion.](#)
114. (pg. 199) The two classes of mutations are nucleotide substitutions and insertions/deletions. Substitutions can result in three types of mutation: silent, missense, and nonsense. Silent mutations are when the substitution results in the same amino acid, causing no noticeable difference in the product. Missense substitutions result in a different amino acid, which could prevent the protein from functioning. Nonsense substitutions change an amino acid into a stop codon, and they typically result in a prematurely terminated protein that cannot function. Insertions and deletions cause frameshift mutations, where if the amino acid(s) is added/removed, the entire mRNA chain is altered, leading to an unreadable message or the production of the wrong protein.
115. (pg. 203) It produces RNA by using a DNA template, which is the reverse of the typical direction of transcription (DNA → RNA). To do this, the HIV virus uses a special enzyme called reverse transcriptase.
116. (pg. 204) The three forms of recombination in bacteria are transformation, transduction, and conjugation. Transformation involves taking in new DNA from the environment, and Transduction involves a bacteriophage inserting DNA into the bacteria and the accidental incorporation of pieces of that DNA into the host's DNA. Conjugation requires the physical connection of two bacterial cells, where one cell replicates its DNA and sends it to the other. That DNA is then added to the recipient cell's DNA via crossing over, and some of the pieces of both the donated DNA and the recipient DNA are degraded.
117. (pg. 205) F factor is a specific piece of DNA in E. coli that allows conjugation to occur. It can either be integrated or become a plasmid. When F factor is integrated into the DNA, it starts replication, but only part of the F factor is transferred over to a recipient. Recombination then occurs via crossing over, creating a recombinant recipient. When the F factor remains as a plasmid, it can initiate replication and completely transfer itself to the recipient. Upon circularization of the new plasmid, the recipient is then referred to as a donor, and both the first donor and the second donor look identical. These plasmids carry other genes, some of which can affect the survival of the cell.